

TUNISIAN CROCHET STITCH GUIDE:
33 Contemporary Stitches

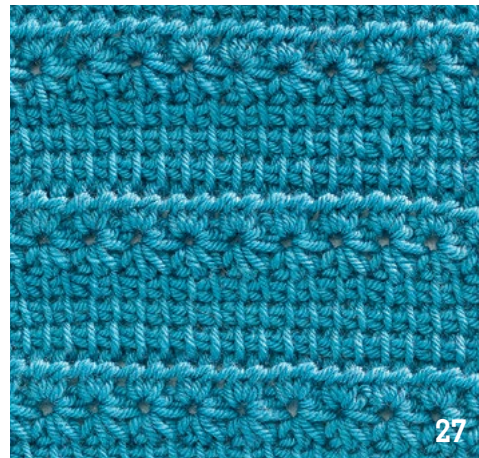

TUNISIAN CROCHET STITCH GUIDE: 33 Contemporary Stitches

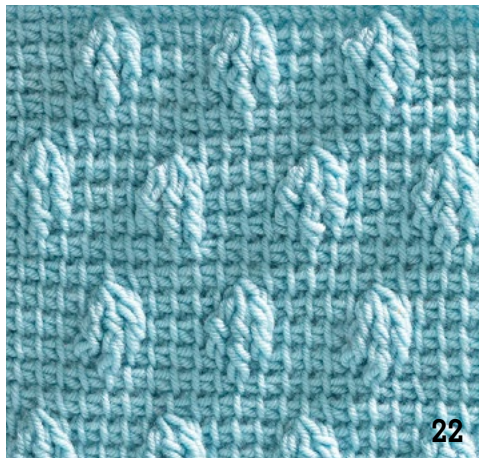
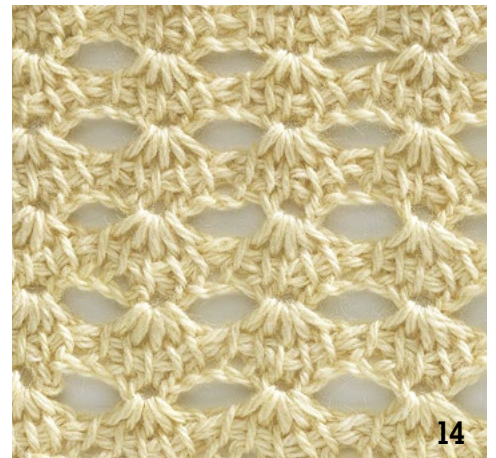
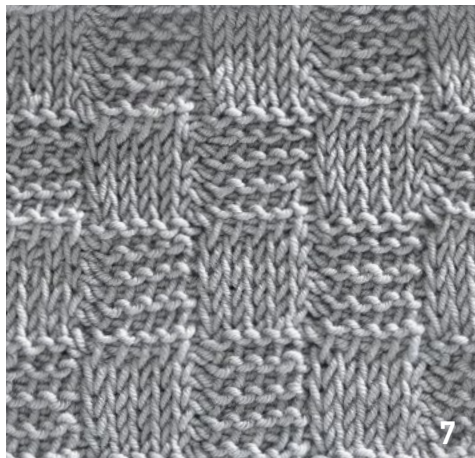
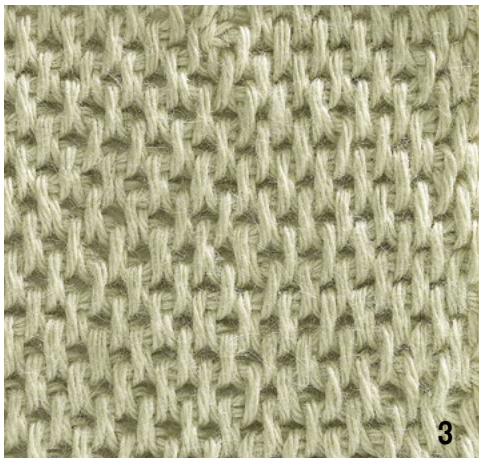

Group One: Basic Stitches.....	Page 3
Group Two: Intermediate Stitch Patterns, Fascinating Fabrics.....	Page 7
Group Three: Lace	Page 14
Group Four: Textured Stitches.....	Page 22
Group Five: Tunisian and Standard Crochet.....	Page 27
Symbol Key.....	Page 30
Glossary.....	Page 31



Almost everything about Tunisian crochet has come under dispute at some point, including its history, origin, attractiveness, utility, and even its name. Perhaps it's this very mystery that entices the modern crocheter to explore the technique. So what is this thing called Tunisian crochet?

Tunisian crochet is often considered to be a hybrid between knitting and crochet and the description is apt. The tool used is a long hook that appears to be a cross between a 14-inch straight knitting needle and

a crochet hook—a long, smooth shaft with a hook at one end and a stopper at the other. Unlike standard crochet, where each stitch is worked and finished as you go, in Tunisian crochet, stitches are picked up in one direction, called the *forward pass*, then finished in the opposite direction, called the *return pass*. The resulting fabric is different from both crochet and knitting, displaying unique qualities all its own.

What's most exciting about this resurgence of interest in Tunisian crochet, beyond the revival of a technique from the past, are the innovations being explored: Newly invented stitches, varieties of Tunisian lace, techniques for working in the round, and new constructions are showing that the technique is just as relevant in the twenty-first century as it was in its earlier incarnations. In this book, I will share with you some of these innovations as well as some reinterpretations of classics.

—Dora Ohrenstein

TUNISIAN CROCHET STITCH GUIDE: 33 Contemporary stitches

EDITORIAL

EDITOR, *CROCHET ME* Toni Rexroat
EDITOR, *INTERWEAVE CROCHET* Marcy Smith
MANAGING EDITOR Allison Mackin
ASSISTANT EDITOR Rachel Koon
PROJECT EDITOR Sarah Read
TECHNICAL EDITOR Karen Manthey

CREATIVE SERVICES

PRODUCTION DESIGNER Janice Tapia
SENIOR PRODUCTION MANAGER Nancy Pollock
PHOTOGRAPHY As noted

PUBLISHING

VICE PRESIDENT, GROUP PUBLISHER Shahla Hebets
eCOMMERCE MARKETING DIRECTOR
Evelyn Bridge
MARKETING MANAGER Annie Hartman Bakken

Projects and information are for inspiration and personal use only. We've made every effort to ensure the accuracy of the contents of this publication. However, human errors do occur. If you have questions regarding a pattern in this issue, please visit us online at www.interweavecrochet.com/corrections.asp.

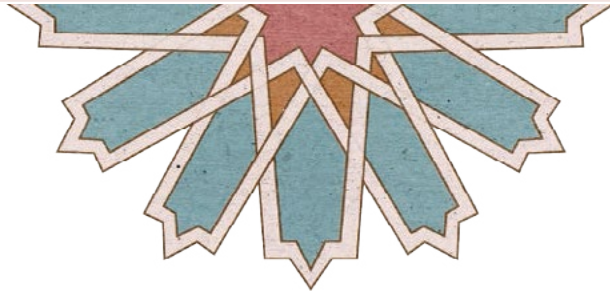

Stitch Dictionary

I wanted to share a large number of stitches in a variety of styles and levels of difficulty. These are by no means exhaustive of all Tunisian stitches, but will give you plenty to work on for a long time to come. I organized the stitches in groups that are similar either in function or technique, starting with simpler stitches and moving gradually to more complex patterns in each group.



GROUP ONE: BASIC STITCHES

This group of stitches allows you to get comfortable with the different strokes of Tunisian crochet—that is, how picking up stitches in various ways creates an array of mesmerizing surface patterns. At the same time, you can get more proficient with the basic stitching technique, which is a bit different from standard crochet.

In Tunisian crochet, tall stitches are the exception rather than the rule, and therefore most stitches behave similarly to single crochet. This is why larger hooks are important for drape: The smaller the stitches, the more dense the fabric. Using a larger hook makes each stitch less dense, which in turn lends greater drape to the fabric.

Since Tunisian crochet is worked in two-part rows consisting of a forward and return pass, the flexibility of stitches, and one's hand movements when making them, is limited. Nevertheless, getting the hang of regulating tension in both directions and on all the different stitches can take some practice.

You'll find that your tension varies from one stitch to another. The return pass, too, is a place to practice tension control. Work too loosely,

and you'll see more curl as the fabric builds up on the wrong side. Work too tightly, and the stitches lack breathing room. Try to find a balance every time you work in Tunisian crochet.

In all the instructions that follow, the loop on the hook counts as the first stitch in the row, so the first stitch you work is the second stitch. Work the last bar under the front and back vertical bars, inserting the hook as in Tss, unless otherwise noted. Work the return passes in the basic manner described in Chapter 2 (page 12) unless otherwise directed.

The reference to “multiples” in the instructions tells you how many stitches are in the pattern repeat, and therefore how many chains to make when starting the stitch pattern. In some cases, it's necessary to make a few extra chains beyond the multiple to accommodate the pattern. In other words, for a pattern with a multiple of 2 stitches, chain any number divisible by 2; for a pattern with a multiple of 4 sts, chain any number divisible by 4. If the instructions say “Multiple of 4 plus 2,” chain any number divisible by 4, then add 2 more chains.

You can find a key to all symbols on page 30.

Stitch 1

NOTE: First and last sts must be staggered row to row to avoid a slanted edge. In one row, draw up lp between the first and 2nd vertical bars, but not between the last 2 bars; in the next row, sk the sp between first and 2nd bars but work a st between the last 2 bars. A slight unevenness along both side edges can be minimized with blocking. Instructions are for

fwd pass; work basic rtn pass throughout patt (see Glossary).

Ch any number. Work basic foundation row (see Glossary).

ROW 1: Tfs between first and 2nd vertical bar, *Tfs between next 2 bars; rep from * across to last 2 bars, sk sp between last 2 sts, draw up lp in last bar.



Stitch 1

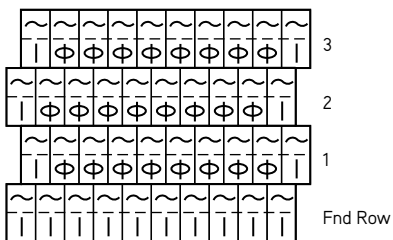

Stitch 2

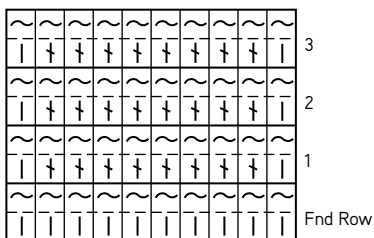

Stitch 3

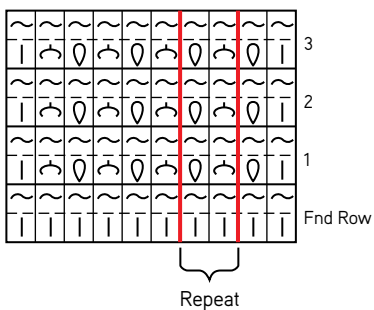

ROW 2: Sk sp between first and 2nd bar, *Tfs between next 2 bars; rep from * across, draw up lp in last bar.

Rep Rows 1–2 for patt.

Stitch 2

TDC: Yo, insert hook as in Tss and draw up lp, yo, draw through 2 lps, leaving 1 lp on hook.

NOTE: Instructions are for fwd pass; work basic rtn pass throughout patt (see Glossary).

Ch any number. Work basic foundation row (see Glossary).

ROW 1: Tdc in each st across (last st should also be Tdc).

Rep Row 1 for patt.

Stitch 3

NOTE: Instructions are for fwd pass; work basic rtn pass throughout patt (see Glossary).

Multiple of 2 sts.

Work basic foundation row (see Glossary).

ROW 1: *Tks, insert hook in bump behind next vertical bar and draw up lp; rep from * across, draw up lp in last bar.

Rep Row 1 for patt.



Stitch 4

NOTES: A combination of Tks and Tunisian crossed sts, this patt can be altered by varying the number of rows between crossed rows. Instructions are for fwd pass; work basic rtn pass throughout patt (see Glossary).

Multiple of 2 sts.

Work basic foundation row (see Glossary).

ROWS 1-4: Tks in each st across, draw up lp in last bar.

ROW 5: *Sk next vertical bar, draw up lp in next vertical bar, draw up lp in skipped bar (Tunisian crossed st made); rep from * across, draw up lp in last bar.

Rep Rows 1-5 for patt.



Stitch 5

NOTE: Instructions are for fwd pass; work basic rtn pass throughout patt (see Glossary).

Multiple of 3 plus 2 sts.

Work basic foundation row (see Glossary).

ROW 1: *Sk next vertical bar, draw up lp in next vertical bar, draw up lp in vertical bar of skipped st (Tunisian crossed st made), Tps in next st; rep from * across, draw up lp in last bar.

ROW 2: *Sk next vertical bar, draw up lp in next vertical bar, draw up lp in vertical bar of skipped st, Tss in next st; rep from * across, draw up lp in last bar.

Rep Rows 1-2 for patt.

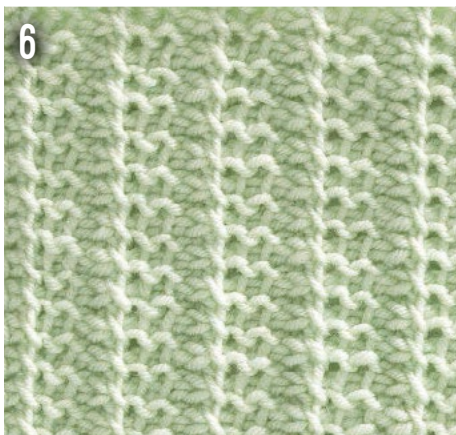

Stitch 6

NOTE: Instructions are for fwd pass; work basic rtn pass throughout patt (see Glossary).

Multiple of 4 plus 2 sts.

Work basic foundation row (see Glossary).

ROW 1: *Sk next vertical bar, draw up lp in next vertical bar, draw up lp in skipped bar (Tunisian crossed st made), work 2 Tps; rep from * across, draw up lp in last bar.

Rep Row 1 for patt.



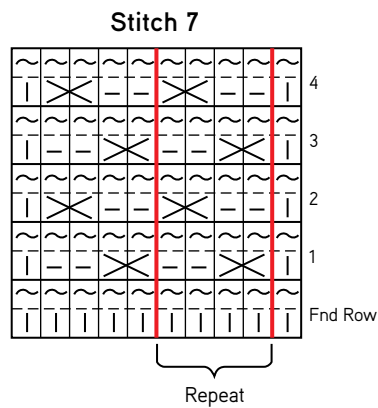
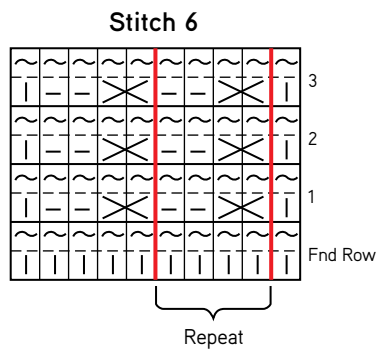
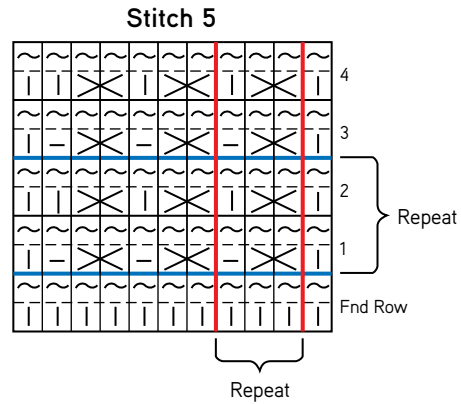
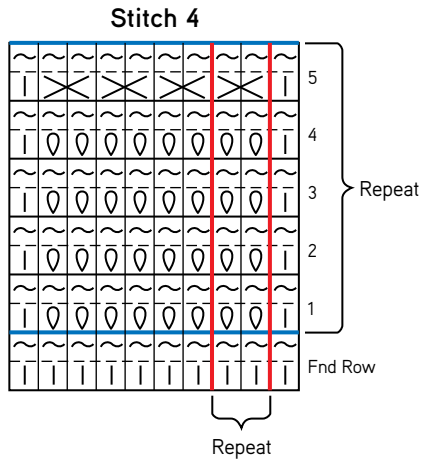

Stitch 7

NOTE: Instructions are for fwd pass; work basic rtn pass throughout patt (see Glossary).

Multiple of 4 plus 2 sts.

Work basic foundation row (see Glossary).

ROW 1: *Sk next vertical bar, draw up lp in next vertical bar, draw up lp in skipped bar

(Tunisian crossed st made), 2 Tps; rep from * across, draw up lp in last bar.

ROW 2: Work 2 Tps, sk next vertical bar, draw up lp in next vertical bar, draw up lp in skipped bar; rep from * across, draw up lp in last bar.

Rep Rows 1–2 for patt.



GROUP TWO: INTERMEDIATE STITCH PATTERNS, FASCINATING FABRICS

As patterns increase in ingenuity, the true wonders of Tunisian crochet are revealed: intricate surface designs unlike anything seen in standard crochet or knitting. These swatches, worked in fingering-weight merino, show the brocade-like beauty that Tunisian crochet can produce. The fabric you see here is suitable in

weight and drape for a range of garments, from vests to cardigans to jackets. In heavier yarns they would make excellent fabric for hats, winter scarves, totes, and afghans. For lighter weight wearables, such as shawls, you'll want to take a look at Group Three, Tunisian lace stitches.



INTERWEAVE CROCHET

Interweave Crochet IS A
MUST-HAVE FOR THOSE WHO
LOVE TO CROCHET!

Every issue includes scrumptious yarns, the latest resources, detailed how-tos, new techniques and exclusive contemporary crochet patterns. You'll find lots of exciting new designs you can wear, use in your home, or give as gifts. Or, maybe you'll find so many exciting crochet projects, you won't know where to start!

interweavecrochet.com

Stitch 8

This basketweave patt can be varied by making more sts in each group, or by making more rows before changing the patt. While Tks and Tps seem to produce the most obvious contrast, other sts can also be used to create a basketweave effect.

NOTE: Include first and last sts in st counts.

Instructions are for fwd pass; work basic rtn pass throughout patt (see Glossary).

Multiple of 10 plus 5 sts.

Work basic foundation row (see Glossary).

ROWS 1-5: Work 4 Tks, work 5 Tps, *work 5 Tks, work 5 Tps; rep from * across to last 5 sts, work 4 Tks, draw up lp in last bar.

ROWS 6-10: Work 4 Tps, work 5 Tks, *work 5 Tps, work 5 Tks; rep from * across to last 5 sts, work 4 Tps, draw up lp in last bar.

Rep Rows 1-10 for patt.

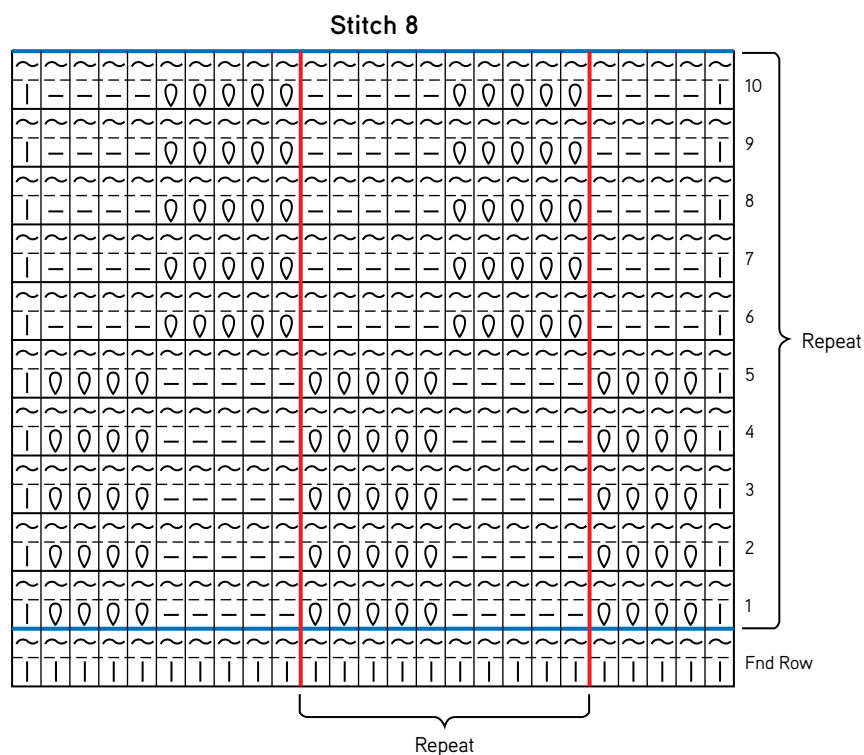
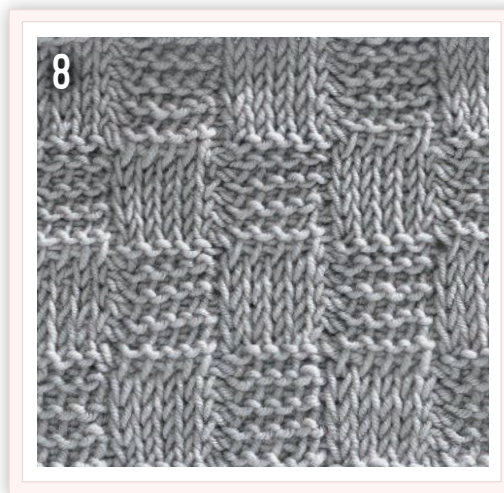

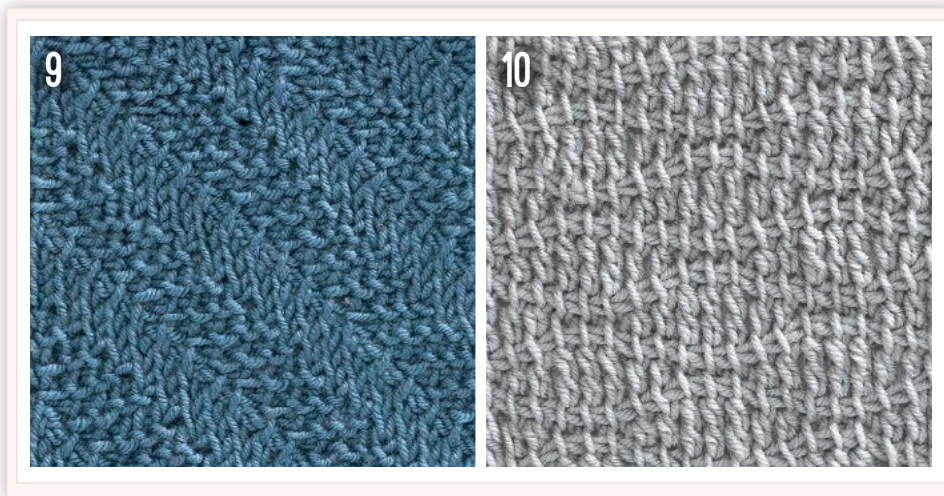

Stitch 9

As in basketweave (Stitch 8), this patt is an example of how sts with different surface textures can be used to form patterns, in this case, diagonal lines. One can use this strategy to create slanted “stripes” of various widths as well as many other effects.

NOTES: Include first and last sts in st counts.
Instructions are for fwd pass; work basic rtn pass throughout patt (see Glossary).

Multiple of 4 sts.

Work basic foundation row (see Glossary).

ROW 1: Work 3 Tks, *work 4 Tps, work 4 Tks; rep from * across to last 4 sts, work 3 Tps, draw up lp in last bar.

ROW 2: Work 4 Tks, *work 4 Tps, work 4 Tks; rep from * across to last 3 sts, work 2 Tps, draw up lp in last bar.

ROW 3: Tps in next st, work 4 Tks, *work 4 Tps, work 4 Tks; rep from * across to last 2 sts, Tps in next st, draw up lp in last bar.

ROW 4: Work 2 Tps, work 4 Tks, *work 4 Tps, work 4 Tks; rep from * across to last st, draw up lp in last bar.

ROW 5: Work 3 Tps, *work 4 Tks, work 4 Tps; rep from * across to last 4 sts, work 3 Tks, draw up lp in last bar.

ROW 6: Tks in next st, work 4 Tps, *work 4 Tks, work 4 Tps; rep from * across to last 3 sts, work 2 Tks, draw up lp in last bar.

ROW 7: Tks in next st, work 4 Tps, *work 4 Tks, work 4 Tps; rep from * across to last 2 sts, Tks in next st, draw up lp in last bar.

ROW 8: Work 2 Tks, work 4 Tps, *work 4 Tks, work 4 Tps; rep from * across to last st, draw up lp in last bar.

Rep Rows 1–8 for patt.

Stitch 10

NOTES: Include first and last sts in st counts.
Instructions are for fwd pass; work basic rtn pass throughout patt (see Glossary).

Multiple of 10 plus 3 sts.

Work basic foundation row (see Glossary).

ROW 1: *Work 2 Tss, work 2 Tdc, work 3 Ttr, work 2 Tdc, work 1 Tss; rep from * across to last 2 sts, Tss in next st, draw up lp in last bar.

ROW 2: Ch 3 (counts as first Ttr), *work 2 Ttr, work 2 Tdc, work 3 Tss, work 2 Tdc, work 1 Ttr; from * across to last 2 sts, Ttr in next st, draw up lp in last bar.

Rep Rows 1–2 for patt.

Stitch 9

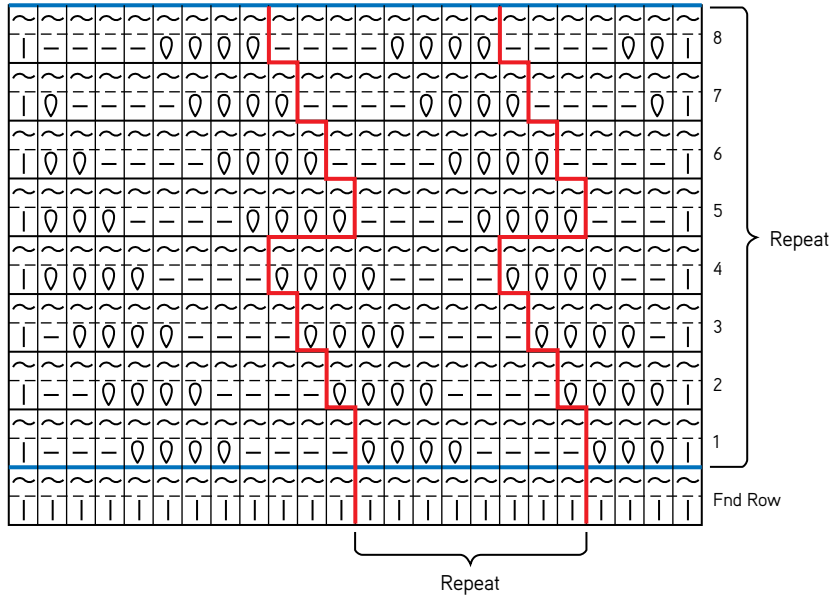

Stitch 10

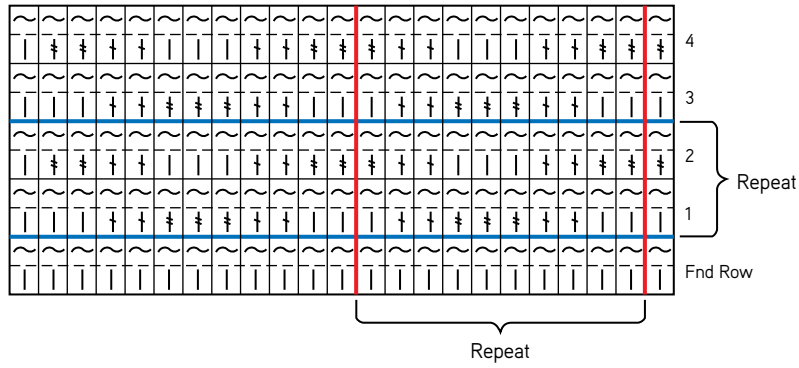

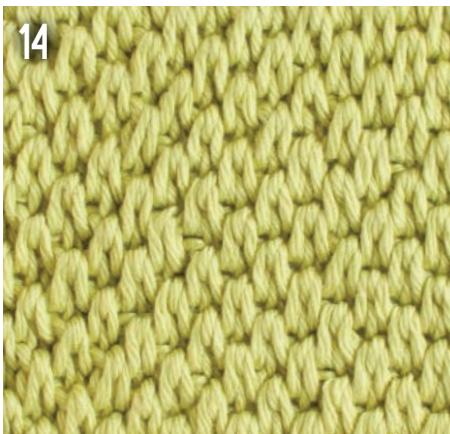
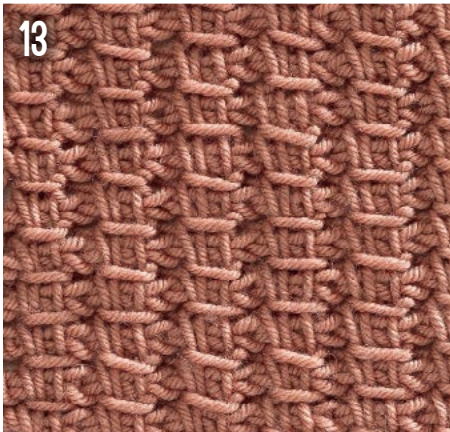

Stitch 11

NOTE: Instructions are for fwd pass; work basic rtn pass throughout patt (see Glossary).

Multiple of 4 plus 2 sts.

Work basic foundation row (see Glossary).

ROW 1: *Work 2 Tdc, work 2 Tps; rep from * across, draw up lp in last bar.

ROW 2: *Work 2 Tps, work 2 Tdc; rep from * across, draw up lp in last bar.

Rep Rows 1–2 for patt.

Stitch 12

TUNISIAN BOBBLE: [Yo, insert hook as in Tss, draw up lp, yo, draw through 2 lps] 4 times, yo, draw through 4 lps on hook leaving lp on hook.

Multiple of 2 plus 1 sts.

Work basic foundation row (see Glossary).

ROW 1: *Fwd:* Ch 1, *bobble (see above) in next vertical bar, sk next st; rep from * across to last 2 sts, bobble in next st, draw up lp in last bar.

Rtn: Yo, draw through 1 lp, *yo, draw through 2 lps, ch 1; rep from * to end.

Rep Row 1 for patt.

LAST ROW: *Tslst in bobble, Tslst in next ch; rep from * across, Tslst in last bar.

Stitch 13

This patt involves an unusual move: bringing a lp over 3 sts at once. Once you get used to it, it can move quite quickly and produces an interesting effect. The patt tends to slant to the right but blocks out evenly.

NOTE: Instructions are for fwd pass; work basic rtn pass throughout patt (see Glossary).

Multiple of 3 plus 2 sts.

Work basic foundation row (see Glossary).

ROW 1: *Yo, work 3 Tss, bring 4th lp to the right over last 3 lps on hook and over end of hook; rep from * across, draw up lp in last bar.

Rep Row 1 for patt.

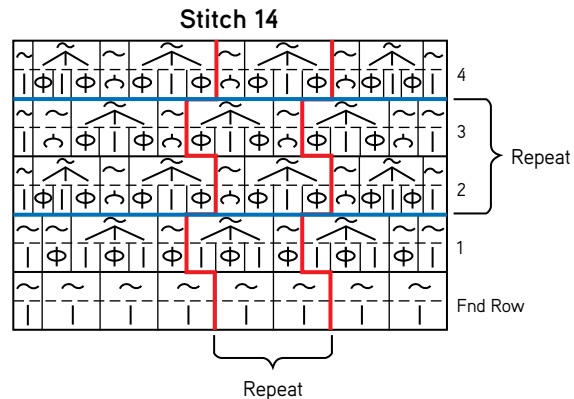
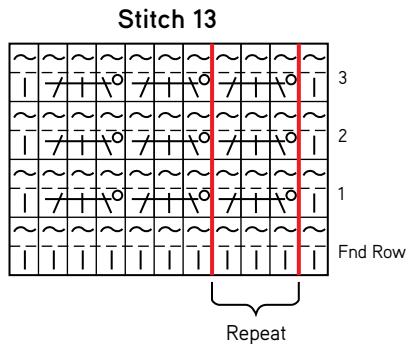
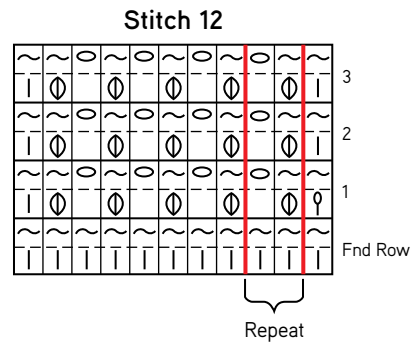
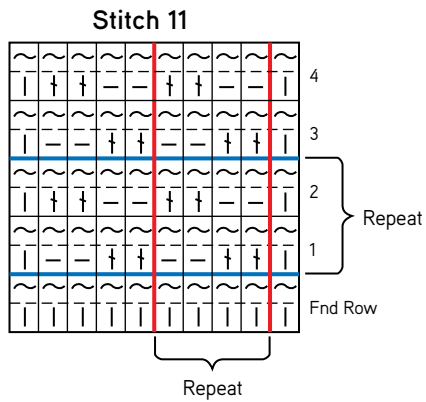

Stitch 14

The Manchester School of Embroidery published a small book in 1907 devoted to Tunisian crochet. Reading the instructions can be challenging, but I have adapted them to contemporary terminology for this pattern, called Gobelin.

NOTE: At the end of the first fwd pass, you will have twice as many lps minus 1 on the hook as your starting ch count.

Multiple of 2 sts.

Work basic foundation row (see Glossary).

ROW 1: *Fwd:* *Tfs in next sp, Tss in next vertical bar; rep from * across, draw up lp in last bar. *Rtn:* Yo, draw through 1 lp, *yo, draw through 4 lps, yo, draw through 2 lps; rep from * across until 2 lps rem on hook, yo, draw through 2 lps.

ROW 2: *Fwd:* *Tfs in next sp, Tss in next vertical bar, Tfs in next sp, draw up lp in bump above next group of 3; rep from * across to last st, Tfs in next sp, draw up lp in last bar. *Rtn:* Yo, draw through 1 lp, *yo draw through 4 lps, yo, draw through 2 lps; rep from * across.

ROW 3: *Fwd:* *Draw up lp in bump behind group of 3, Tfs in next sp, Tss in next vertical bar, Tfs in next sp; rep from * across to last 2 sts, draw up lp in bump behind group of 3, draw up lp in last bar. *Rtn:* Yo, draw through 1 lp, yo, draw through 2 lps, *yo draw through 4 lps, yo, draw through 2 lps; rep from * across until 2 lps rem on hook, yo, draw through 2 lps.

Rep Rows 2–3 for patt.

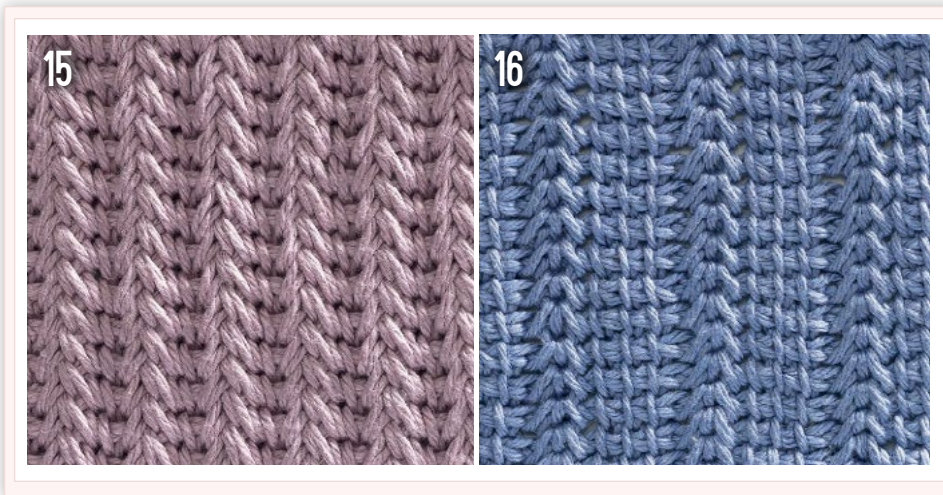

Stitch 15

NOTE: At the end of the first fwd pass, you will have twice as many lps minus 1 on the hook as your starting ch count.

Multiple of 4 plus 1 sts.

Work basic foundation row (see Glossary).

ROW 1: *Fwd:* *Tfs in next sp, Tss in next vertical bar; rep from * across. *Rtn:* Yo draw through 1 lp, *yo, draw through 4 lps, yo, draw through 2 lps; rep from * across.

ROW 2: *Fwd:* Tfs in next sp, insert hook under 3-st cluster and draw up lp, Tfs in next sp, Tss in next vertical bar; rep from * across, Tfs in last sp, draw up lp in last st. *Rtn:* Work as for rtn in Row 1.

Rep Row 2 for patt.

Stitch 16

Multiple of 5 plus 2.

FOUNDATION ROW: *Fwd:* Work as for basic foundation row (see Glossary). *Rtn:* Yo, draw through 1 lp, [yo, draw through 2 lps] twice, *ch 1, yo, draw through 4 lps, ch 1, [yo, draw through 2 lps] 3 times; rep from * across.

ROW 1: *Fwd:* Work 2 Tss, *draw up lp in blp of ch, insert hook under 3-st cluster and draw up lp, draw up lp in blp of ch, work 3 Tss; rep from * across, ending with draw up lp in last bar. *Rtn:* Work as for foundation row.

Stitch 15

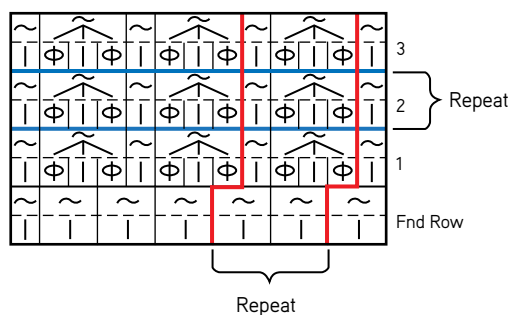

Stitch 16

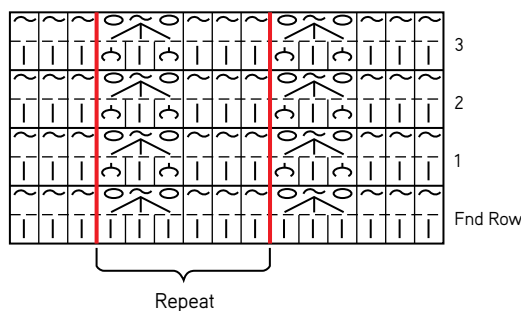

Rep Row 1 for patt.

FINISHING ROW: Tslst in each Tss and in blp of each ch across.



GROUP THREE: LACE

Becoming comfortable with Tunisian lace requires learning a few new techniques. For one, making yarnovers in the forward pass, a very simple maneuver, and working them off, which is simply a matter of remembering they are there and knowing how to recognize them. When picking up stitches in the yarnovers, you can identify them by their slant from right to left.

On the return pass, you will sometimes be making chains to stand in for clustered stitches on the forward pass, in the same way you make chains over groups of stitches in standard crochet. It can take some time to get used to doing it in reverse.

Having chains in the return pass requires mastery of another technique: working into those chains on the forward pass. If chains are worked too tightly, they can be nearly

impossible to work into on the next forward pass. Counting the chains correctly is another skill to build, though usually there are only two or three in sequence.

When making lace, the role of the return pass becomes increasingly powerful in creating patterned groups of stitches. Yarnovers become more common. By the time you arrive at some of the advanced lace patterns here, you will be varying stitches on both the forward and return passes in great detail, requiring some serious concentration, but it will be well worth the effort.

The swatches here are all worked in Manos del Uruguay Serena, a fingering-weight silk/alpaca blend that brings out as much slinkiness as one could desire. All could easily become shawls, and there are lovely fabrics here for any number of drapey wearables, such as summer cardigans.



Stitch 17

NOTES: Make sure not to miss the last yo in the row, which can disappear into the horizontal bar. Instructions are for fwd pass; work basic rtn pass throughout patt (see Glossary). Do not work foundation row.

Multiple of 2 sts.

ROW 1: Tss in 2nd ch from hook, *yo, sk next ch, Tss in next ch; rep from * across.

ROW 2: *Yo, sk next vertical bar, Tfs in next sp; rep from * across to last st, draw up lp in last bar.

ROW 3: *Tfs in next sp, **yo, sk next vertical bar; rep from * across, ending last rep at **, draw up lp in last bar.

Rep Rows 2–3 for patt.

FINISHING ROW: *Sk next vertical bar, sl st in next ch of horizontal bar, draw up lp in next yo and sl st; rep from * across.

Stitch 18

TSS2TOG: Insert hook under next 2 bars, draw up lp.

NOTE: Instructions are for fwd pass; work basic rtn pass throughout patt (see Glossary).

Multiple of 2 sts.

Work basic foundation row (see Glossary).

ROW 1: *Tss2tog, yo; rep from * across, draw up lp in last bar.

ROW 2: *Tss in next st, Tfs in next sp; rep from * across, draw up lp in last bar.

Rep Rows 1–2 for patt.

FINISHING ROW: *Insert hook as in Tss2tog and sl st, sl st in flp of horizontal bar; rep from * across.

Stitch 17

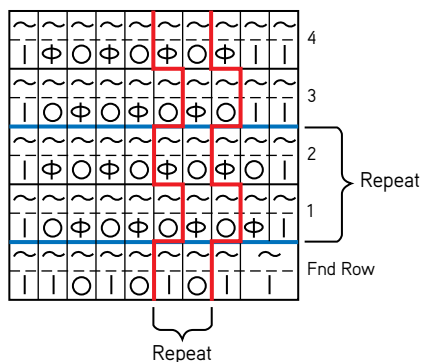

Stitch 18

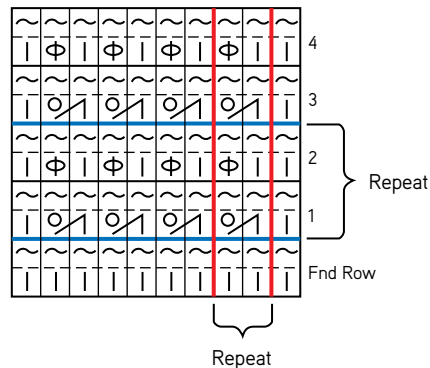

Stitch 19

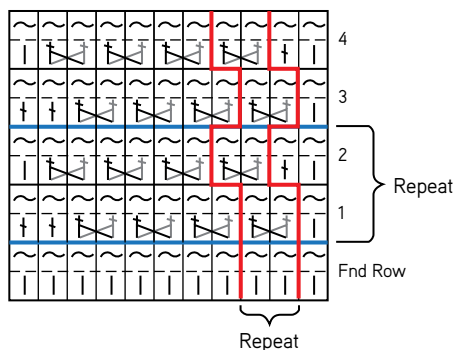

Stitch 20

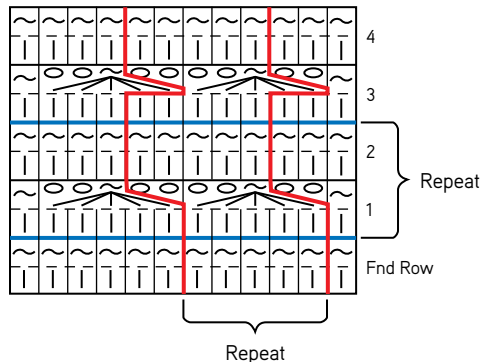

Stitch 19

TDC UNDER 2 VERTICAL BARS: Yo, insert hook under next 2 vertical bars, draw up lp, [yo, draw through 2 lps] twice, leaving 1 lp on hook.

NOTE: Instructions are for fwd pass; work basic rtn pass throughout patt (see Glossary).

Multiple of 2 plus 1 st.

Work basic foundation row (see Glossary).

ROW 1: Ch 1, *Tdc under next 2 vertical bars, Tdc under same 2 bars; rep from * across to last 2 sts, Tdc in next bar, Tdc in last bar.

ROW 2: Ch 1, Tdc in next bar, *Tdc under next 2 vertical bars, Tdc under same 2 bars; rep from * across to last bar, Tdc in last bar.

Rep Rows 1–2 for patt.

Stitch 20

Multiple of 5 plus 2 sts.

Work basic foundation row (see Glossary).

ROW 1: *Fwd:* Tss across, draw up lp in last bar.

Rtn: Yo, draw through one lp, ch 2, *yo, draw through 6 lps**, ch 4; rep from * across, ending last rep at **, ch 2, yo, draw through 2 lps.

ROW 2: Tss across, draw up lp in last bar.

Rep Rows 1–2 for patt.



21

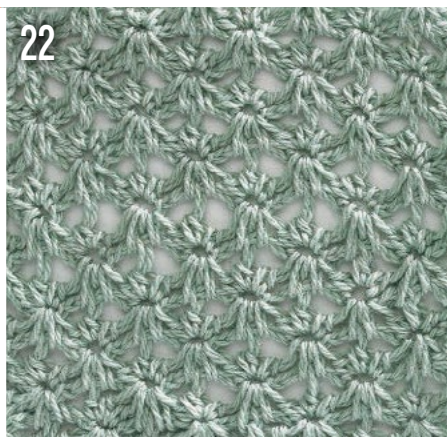

22

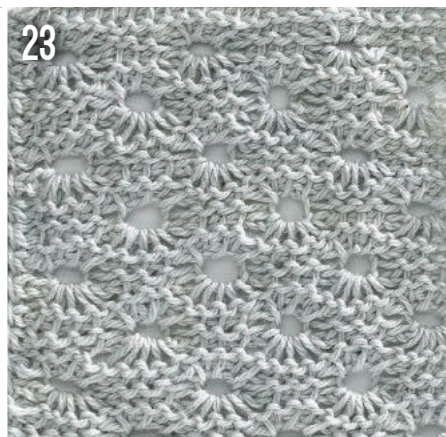

23

Stitch 21

TDC2TOG: (Yo, insert hook in indicated st, yo, draw up lp, yo, draw through 2 lps) twice (3 lps on hook), yo, draw through 2 lps, leaving 1 lp on hook.

NOTE: Do not work foundation row. Work Row 1 sts into blp of foundation ch.

Multiple of 4 plus 1 sts.

ROW 1: *Fwd:* Tps in 2nd ch from hook, sk next ch, *Tdc2tog in next ch**, sk next ch, Tps in next ch, sk next ch; rep from * across, ending last rep at **, draw up lp in last ch. *Rtn:* Yo, draw through 1 lp, *yo, draw through 2 lps, ch 1; rep from * across until 3 lps rem on hook, [yo draw through 2 lps] twice.

ROW 2: *Fwd:* Tdc2tog (see above) in next bar, sk next ch, Tps in next st**, sk next ch; rep from * across ending last rep at **, draw up lp in last bar. *Rtn:* Work as for Row 1.

ROW 3: *Fwd:* Tps in next st, sk next ch, *Tdc2tog in next st**, sk next ch, Tps in next st, sk next ch; rep from * across, ending last rep at **, draw up lp in last bar. *Rtn:* Work as for Row 1.

Rep Rows 2–3 for patt.

NOTE: Patt can end either with Row 2 or 3. No sl st row required to finish this patt.

Stitch 22

NOTE: In rtn passes, 5 sts are gathered to make an upside-down fan. On the next fwd pass, work into the ch that sits atop the fan.

Multiple of 6 plus 5 sts.

Work basic foundation row (see Glossary).

ROW 1: *Fwd:* Tdc in next 2 sts, *Tss in next 3 sts, Tdc in next 3 sts; rep from * across to last 2 sts, Tss in next st, draw up lp in last bar. *Rtn:* Yo, draw through 3 lps (half fan made), *ch 2, yo, draw through 2 lps, ch 2, yo, draw through 6 lps (fan made); rep from * across until 3 lps rem on hook, ch 2, [yo, draw through 2 lps] twice.

ROW 2: *Fwd:* Tss in next st, Tfs in next sp, *3 Tdc in top of fan, Tfs in next sp, Tss in next st, Tfs in next sp; rep from * across, 2 dc in top of half fan. *Rtn:* Yo, draw through 1 lp, *ch 2, yo, draw through 6 lps, ch 2, yo, draw through 2 lps; rep from * across until 5 lps rem on hook, ch 2, yo, draw through 4 lps (half fan made), yo, draw through 2 lps.

ROW 3: *Fwd:* 2 Tdc in top of half fan, *Tfs in next sp, Tss in next st, Tfs in next sp, 3 Tdc in top of fan; rep from * across, Tfs in next sp, draw up lp in last bar. *Rtn:* Work as for Row 1.

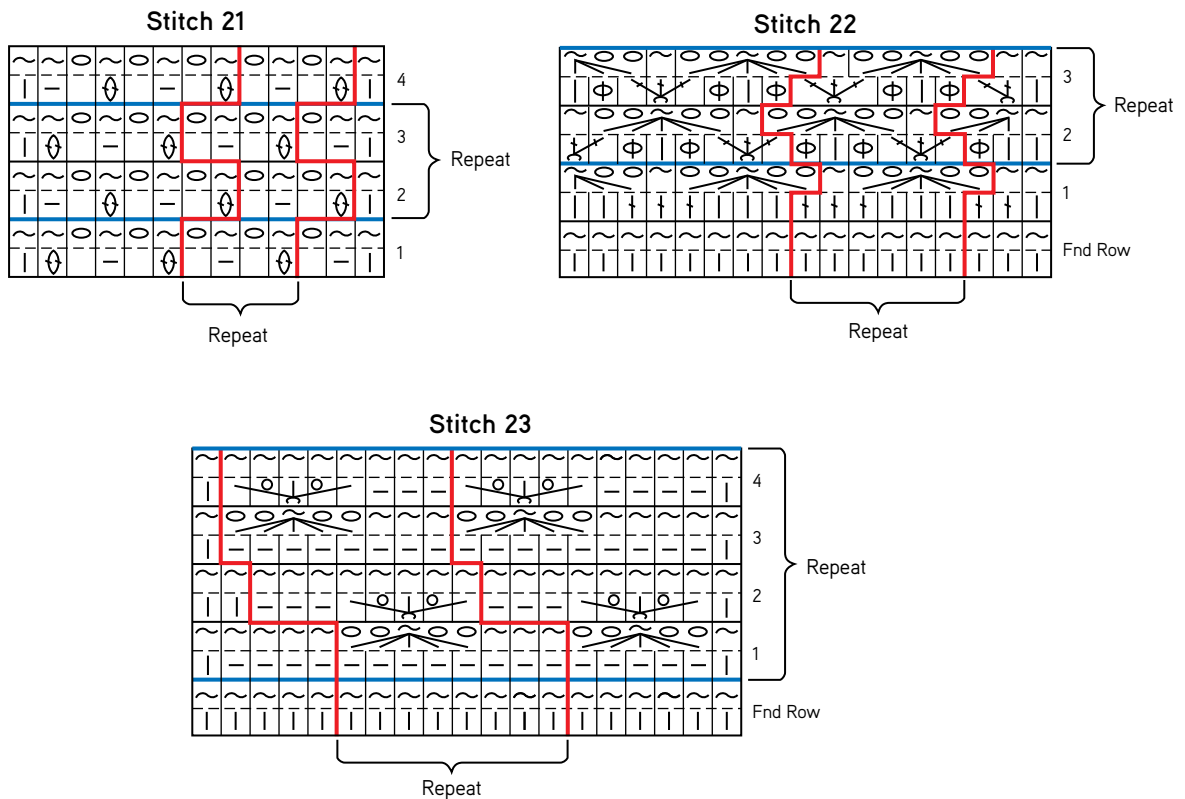

Stitch 23

Five loops are gathered on return passes to create the bottom of this floral design. The top of the flower is made on the forward pass by working into the bump at the back of the gathered stitches, with yarnovers used at these spots to create space between stitches. On the return pass, work off these yarnovers as stitches. Work loosely throughout.

Multiple of 8 plus 4 sts.

Work basic foundation row (see Glossary).

ROW 1: *Fwd:* Tps in each st across, draw up lp in last bar. *Rtn:* Yo, draw through 1 lp, [yo, draw through 2 lps] 4 times, *ch 2, yo draw through 6 lps, ch 2**, [yo draw through 2 lps] 3 times; rep from * across, ending last rep at **, [yo draw through 2 lps] twice.

ROW 2: *Fwd:* Tss in next st, in bump behind group of 5 work (Tss, yo, Tss, yo, Tss), work 3 Tps; rep from * across to last 2 sts, Tss in next st, draw up lp in last bar. *Rtn:* Work basic rtn pass (see Glossary).

ROW 3: *Fwd:* Tps in each st across, draw up lp in last bar. *Rtn:* Yo, draw through 1 lp, *ch 2, yo, draw through 6 lps, ch 2, [yo, draw through 2 lps] 3 times; rep from * across until 4 lps rem on hook, [yo, draw through 2 lps] 3 times.

ROW 4: *Fwd:* Tss in next st, *work 3 Tps, in bump behind next group of 5 work (Tss, yo, Tss, yo, Tss); rep from * across, draw up lp in last bar. *Rtn:* Work basic rtn pass.

Rep Rows 1–4 for patt. End after any even row. Work basic finishing row inserting hook as in Tps.

24

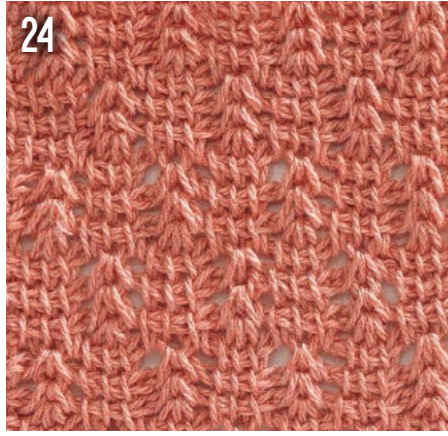

25



Stitch 24

Multiple of 6 plus 5 sts.

Work basic foundation row (see Glossary).

ROW 1: *Fwd:* Tss in each st across, draw up lp in last bar. *Rtn:* Yo, draw through 1 lp, *[yo, draw through 2 lps] 3 times, ch 1, yo, draw through 3 lps, ch 1; rep from * across until 5 lps rem on hook, [yo draw through 2 lps] 4 times.

ROWS 2-3: *Fwd:* *Work 3 Tss, Tfs in next sp, draw up lp in bump behind group of 3, Tfs in next sp; rep from * across to last 4 sts, Tss in next 3 sts, draw up lp in last bar. *Rtn:* Work as for Row 1 rtn.

ROW 4: *Fwd:* Work as for Row 2 fwd. *Rtn:* Yo, draw through 1 lp, *ch 1, yo, draw through 3 lps, ch 1**, [yo, draw through 2 lps] 3 times; rep from * across, ending last rep at **, yo draw through 2 lps.

ROWS 5-6: *Fwd:* *Tfs in next sp, draw up lp in bump behind group of 3, Tfs in next sp**, work 3 Tss; rep from * across, ending last rep at **, draw up lp in last bar. *Rtn:* Yo, draw through 1 lp, *ch 1, yo, draw through 3 lps, ch 1**, [yo, draw through 2 lps] 3 times; rep from * across, ending last rep at **, yo, draw through 2 lps.

ROW 7: *Fwd:* Work as for Row 5 fwd. *Rtn:* Work as for Row 1 rtn.

Rep Rows 2-7 for patt, ending with Row 6.

LAST ROW: Working as in Tss, Tslst in each st across.

Stitch 25, Lace Diamonds by Natasha Robarge

TSS2TOG: Insert hook in next 2 bars, draw up lp.

NOTE: Instructions are for fwd pass; work basic rtn pass throughout patt (see Glossary).

Multiple of 8 plus 5 sts.

Work basic foundation row (see Glossary).

ROW 1: Work 5 Tss, *yo, sk next st, work 7 Tss; rep from * across, yo, sk next st, work 5 Tss, draw up lp in last bar.

ROW 2: Work 3 Tss, *Tss2tog, yo, Tfs in next sp, yo, Tss2tog, work 3 Tss; rep from * across, draw up lp in last bar.

ROW 3: Work 2 Tss, *Tss2tog, yo, Tfs in next sp, Tss in next bar, Tfs in next sp, yo, Tss2tog, Tss in next bar; rep from * across, work 2 Tss, draw up lp in last bar.

ROW 4: Work 2 Tss, Tss2tog, yo, *Tfs in next sp, work 3 Tss, Tfs in next sp, yo**, Tss3tog, yo; rep from * across, ending last rep at **, Tss2tog, Tss in next bar, draw up lp in last bar.

ROW 5: Tss in next bar, Tss2tog, yo, *Tfs in next sp, work 5 Tss, Tfs in next sp**, yo, sk next st; rep from * across, ending last rep at **, yo, Tss2tog, draw up lp in last bar.

ROW 6: Tss in next bar, Tfs in next sp, *yo, Tss2tog, work 3 Tss Tss2tog, yo, Tfs in next sp; rep from * across, Tss in next bar, draw up lp in last bar.

Stitch 24

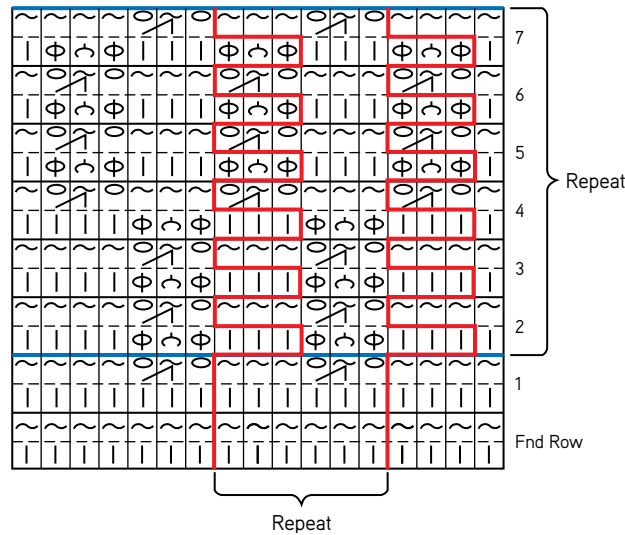

Stitch 25, Lace Diamonds

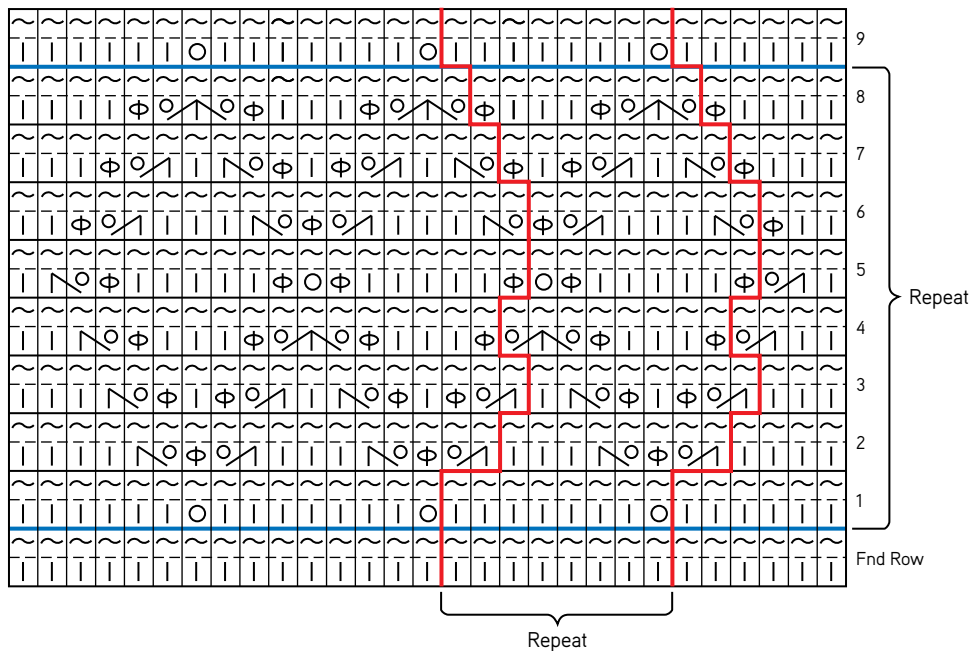

ROW 7: Work 2 Tss, Tfs in next sp, *yo, Tss2tog, Tss in next bar, Tss2tog, yo, Tfs in next sp**, Tss in next bar, Tfs in next sp; rep from * across, ending last rep at **, work 2 Tss, draw up lp in last bar.

ROW 8: Work 3 Tss, Tfs in next sp, *yo, Tss3tog, yo, Tfs in next sp, work 3 Tss**, Tfs in next sp; rep from * across, ending last rep at **, draw up lp in last bar.

Rep Rows 1–8 for patt.



Stitch 26, Lace Wave by Natasha Robarge

NOTE: Instructions are for fwd pass; work basic rtn pass throughout patt (see Glossary).

Multiple of 8 plus 3 sts.

Work basic foundation row (see Glossary).

ROW 1: Tss in each st across, draw up lp in last bar.

ROW 2: Work 4 Tss, *yo, Tss2tog**, work 6 Tss; rep from * across, ending last rep at **, work 3 Tss, draw up lp in last bar.

ROW 3: Work 2 Tss, *Tss2tog, yo, Tfs in next sp, yo, Tss2tog**, work 3 Tss; rep from * across, ending last rep at **, draw up lp in last bar.

ROW 4: Tss in next bar, *Tss2tog, yo, Tfs in next sp, Tss in next bar, Tfs in next sp, yo, Tss2tog, Tss in next bar; rep from * across, draw up lp in last bar.

ROW 5: Work Tss2tog, yo, *Tfs in next sp, work 3 Tss, Tfs in next sp, yo**, Tss3tog, yo; rep from * across, ending last rep at **, Tss2tog, draw up lp in last bar.

Rep Rows 2–5 for patt.

Stitch 26, Lace Wave

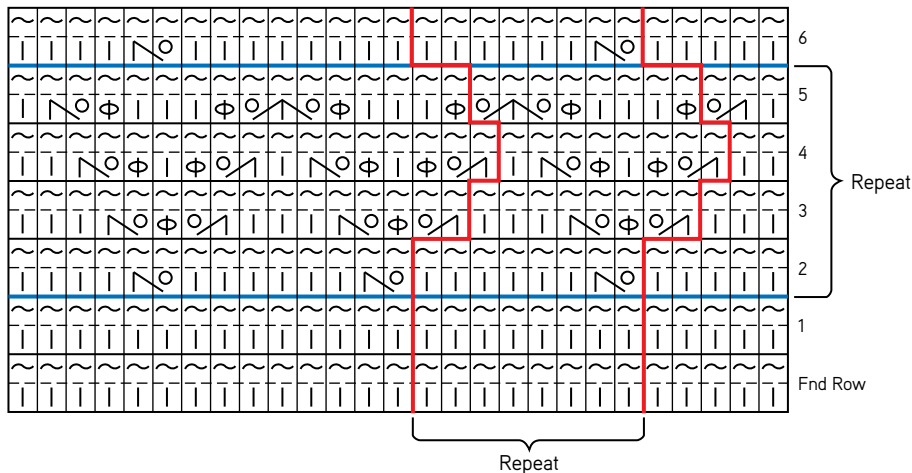



GROUP FOUR: TEXTURED STITCHES

These patterns use raised stitches, similar to post stitches in standard crochet, to create dimensional surfaces. Because there aren't too many posts to work around in Tunisian crochet, to create surface texture we work into the vertical bars two or three rows before the working row. Work the long stitches loosely to keep the fabric lying flat. Use your judgment.



INTERWEAVE KNITS

Discover knitwear designs that will capture your imagination.

You don't have to be a designer or a knitting pro to make beautiful knitted garments and accessories, and you don't have to hunt all over for inspiring designs.

From cover to cover, *Interweave Knits* magazine gives you great projects, from the beginner to the advanced. Every issue is packed full of captivating smart designs, step-by-step instructions, easy-to-understand illustrations, plus well-written, lively articles sure to inspire.

interweaveknits.com



Stitch 27

LONG TDC: Yo, insert hook in vertical bar of next st 2 rows below, draw up lp, [yo, draw through 2 lps] twice, leaving 1 lp on hook.

NOTE: Instructions are for fwd pass; work basic rtn pass throughout patt (see Glossary).

Multiple of 2 plus 1 st.

Work basic foundation row (see Glossary).

ROW 1: Tss in each st across, draw up lp in last bar.

ROW 2: *Long Tdc (see above) in next st 2 rows below**, Tss in next st; rep from * across, ending last rep at **, draw up lp in last bar.

ROW 3: *Tss in next st**, long Tdc in next st 2 rows below; rep from * across, ending last rep at **, draw up lp in last bar.

Rep Rows 2–3 for patt.

Stitch 28

LONG TDC: Yo, insert hook in vertical bar of next st 2 rows below, draw up lp, [yo, draw through 2 lps] twice, leaving 1 lp on hook.

LONG TTR: Yo twice, insert hook in vertical bar of next st 2 rows below, draw up lp, [yo, draw through 2 lps] 3 times, leaving 1 lp on hook.

NOTES: Instructions are for fwd pass; work basic rtn pass throughout patt (see Glossary). To create a 2-color version of this patt, beg at Row 3 work fwd and rtn of every odd-numbered row in 2nd color.

Multiple of 3 plus 2 sts.

Work basic foundation row (see Glossary).

ROW 1: Tps in next st, *long Tdc (see above) in foundation ch below Foundation Row, work 2 Tps; rep from * across to last 2 sts, Tps in next st, draw up lp in last bar.

ROWS 2–3: Tss in each st across, draw up lp in last bar.

ROW 4: Tps in next st, *long Ttr (see above) in next st 3 rows below, work 2 Tps; rep from * across to last 2 sts, Tps in next st, draw up lp in last bar.

Rep Rows 2–4 for patt.

LAST ROW: Working as in Tps, Tslst in each st across.

Stitch 29

TTR3TOG (CLAW): Yo twice, insert hook in vertical bar 1 st to the right of working st and 3 rows below, [yo, draw through 2 lps] twice, yo twice, insert hook in vertical bar of next st 4 rows below, [yo, draw through 2 lps] twice, yo twice, insert hook in vertical bar of next st 3 rows below, [yo, draw through 2 lps] twice, yo, draw through 3 lps on hook, leaving 1 lp on hook.

NOTE: Instructions are for fwd pass; work basic rtn pass throughout patt (see Glossary).

Multiple of 6 plus 1 sts.

Work basic foundation row (see Glossary).

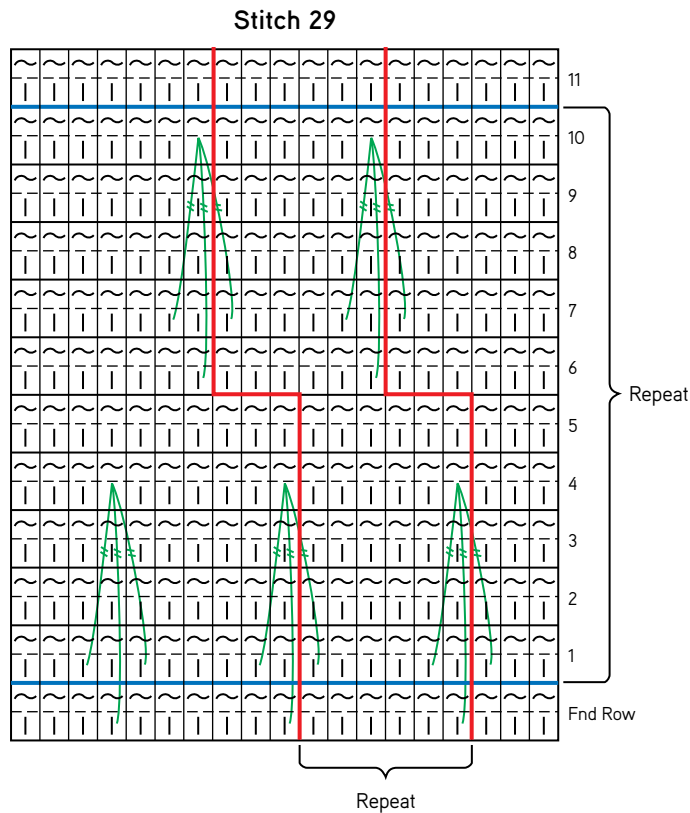
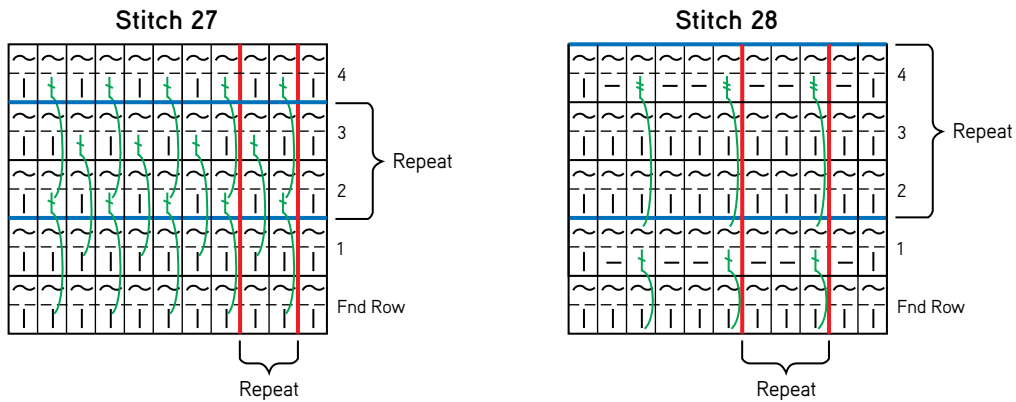

ROWS 1-3: Tss in each st across, draw up lp in last bar.

ROW 4: Tss in next 2, *Ttr3tog (see above), sk st behind claw**, Tss in next 5 sts; rep from * across, ending last rep at **, Tss in next 2 sts, draw up lp in last bar.

ROWS 5-9: Tss in each st across, draw up lp in last bar.

ROW 10: Work 5 Tss, *Ttr3tog, Tss in next 5 sts; rep from * across, draw up lp in last bar.

ROW 11: Tss in each st across, draw up lp in last bar.

Rep Rows 1-10 for patt.



Stitch 30

TDC2TOG: [Yo, insert hook in front bar of specified st 3 rows below, yo, draw through st and up to level of current row, yo, draw yarn through 2 lps on hook] twice in same st, yo, draw through 2 lps on hook.

NOTES: When working Tdc2tog in Row 5, make sure not to work into vertical bar behind st. When working Tdc2tog in Row 6, sk the vertical bar behind the st, but make sure not to miss the next st, which is obscured because the st is worked on a slant. Instructions are for fwd pass; work basic rtn pass (see Glossary) unless otherwise directed.

Multiple of 8 plus 4 sts.

Work basic foundation row (see Glossary).

ROWS 1-3: Tss in each st across, draw up lp in last bar.

ROW 4: Work 4 Tss in next st, *Tdc2tog (see above) around front bar of next st 3 rows below**, work 7 Tss; rep from * across, ending last rep at **, work 5 Tss, draw up lp in last bar.

ROW 5: *Fwd:* Work 5 Tss, *Tdc2tog around front bar of next st to the left of working st, 3 rows below**, work 7 Tss; rep from * across, ending last rep at **, work 4 Tss, draw up lp in last bar. *Rtn:* Yo, draw through 1 lp, (yo, draw through 2 lps) 4 times, *ch 1, yo, draw through 3 lps on hook**, [yo, draw through 2 lps] 6 times; rep

from * across, ending last rep at **, [yo, draw yarn through 2 lps] 5 times.

ROW 6: Work 5 Tss, *insert hook under 2 gathered lps for next Tfs, draw up lp in ch**, work 7 Tss; rep from * across, ending last rep at **, work 4 Tss, draw up lp in last bar.

ROWS 7-10: Tss in each st across, draw up lp in last bar.

Rep Rows 4-10 for patt, ending with Row 7.

Stitch 31, TC Cable by Natasha Robarge

NOTE: Instructions are for fwd pass; work basic rtn pass throughout patt (see Glossary).

Multiple of 10 plus 4 sts.

Work basic foundation row (see Glossary).

ROWS 1-6: Work 3 Tps, *work 6 Tss**, work 4 Tps; rep from * across, ending last rep at **, work 3 Tps, draw up lp in last bar.

ROW 7: Work 3 Tps, *sk next 3 sts, draw up lp in each of next 3 bars, draw up lp in each of 3 skipped bars**, work 4 Tps; rep from * across, ending last rep at **, work 3 Tps, draw up lp in last bar.

ROWS 8-12: Rep Row 1.

Rep Rows 7-12 for patt.

Stitch 30

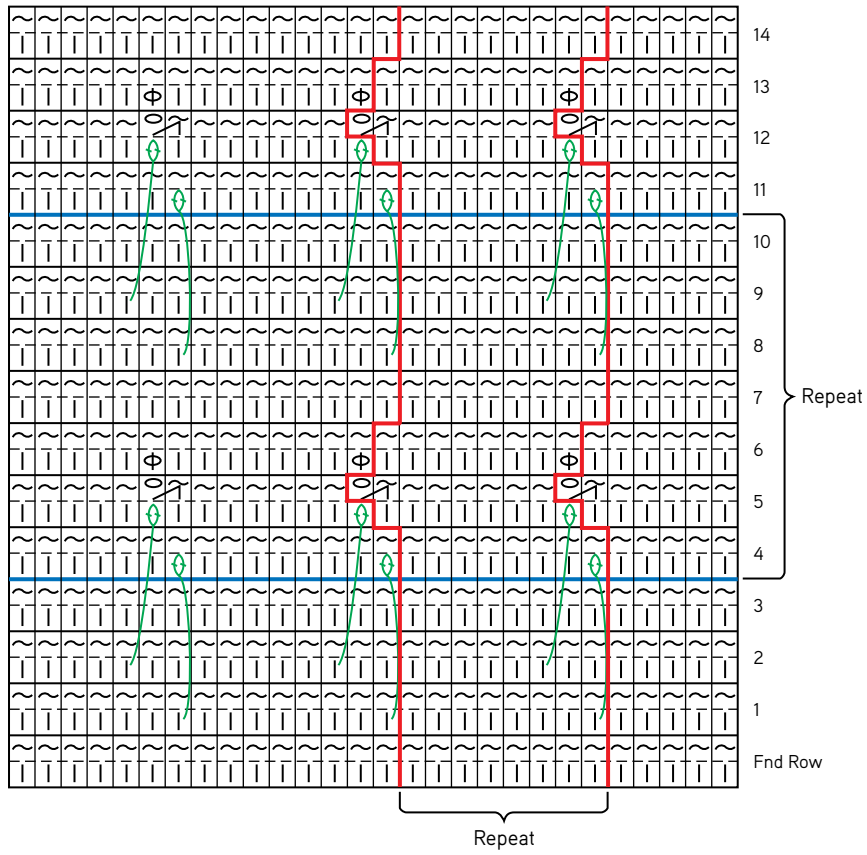

Stitch 31, TC Cable

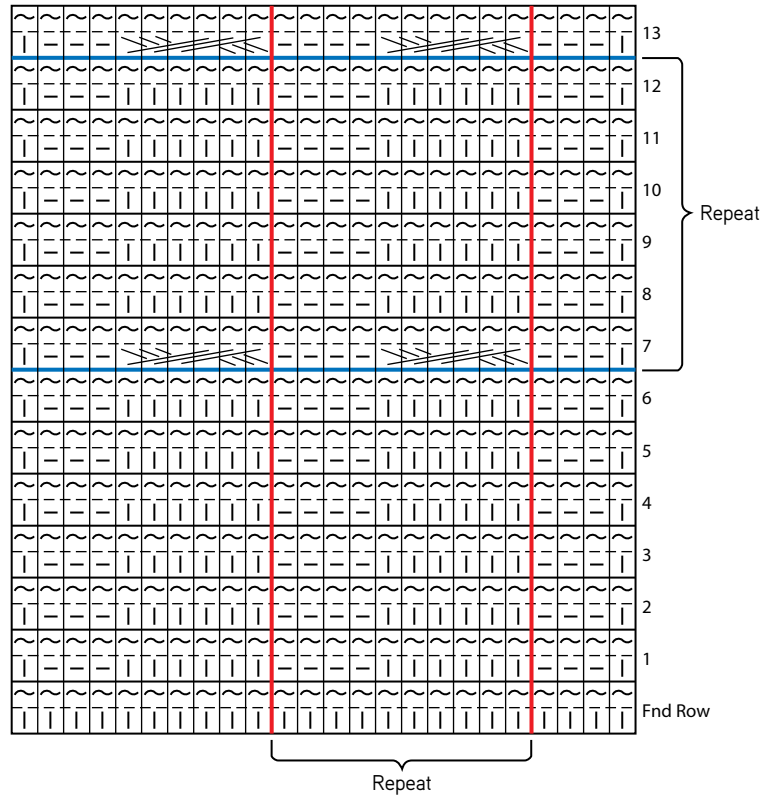



GROUP FIVE: TUNISIAN AND STANDARD CROCHET

Many possibilities exist for combining these two techniques. The first pattern uses a diamond shape to create an effect similar to entrelac. The second capitalizes on the similarity between how stitches are picked up for marguerites and how they are done in Tunisian crochet. I used the same hook in both techniques, but if you find your gauges are not matching when going from one technique to the other, feel free to change hook sizes.

Stitch 32

I adapted this from a stitch introduced to me by designer Margaret Hubert. It's a combination of a well-loved pattern from standard crochet (sometimes called diamonds) and angled boxes consisting of Tss. The upside-down fans fit into the points between angled squares. After completing the diamonds, a row of slip stitches keeps all Tunisian rows facing the same side.

NOTE: When working the Tss boxes, the beg of each rtn pass is linked to the previous row by slip stitching into it (as described in instructions that follow). This sl st serves as the ch-1 that usually begins a rtn pass. This method causes the last st in the row to look shorter than the others; be sure not to miss it when working fwd pass. The fabric opens up again when more rows are completed.

Ch multiple of 8 plus 4.

ROW 1 (STANDARD CROCHET): 4 dc in 4th ch from hook, *sk next 3 ch, sc in next ch**, sk 3 ch, 9 dc in next ch; rep from * across, ending last rep at **, sk next 3 ch, 5 dc in last ch, turn.

ROW 2 (STANDARD CROCHET): Ch 1, sl st in each st across, turn.



ROW 3 (TUNISIAN SQUARES):

ROW A (TUNISIAN): *Fwd: Lp on hook counts as first st, [draw up lp in next sl st] 4 times, draw up lp in next sl st (over sc)—6 lps on hook.

Rtn: Insert hook in sl st on top of next dc, yo, draw yarn through st and lp on hook, [yo, draw through 2 lps] 5 times—6 Tss.

ROWS B, C, AND D (TUNISIAN): *Fwd:* Work 5 Tss.

Rtn: Work as for Row A rtn.

ROW E: Tslst in each bar across, sl st in sl st on top of center dc of next 9-dc shell.

Stitch 32

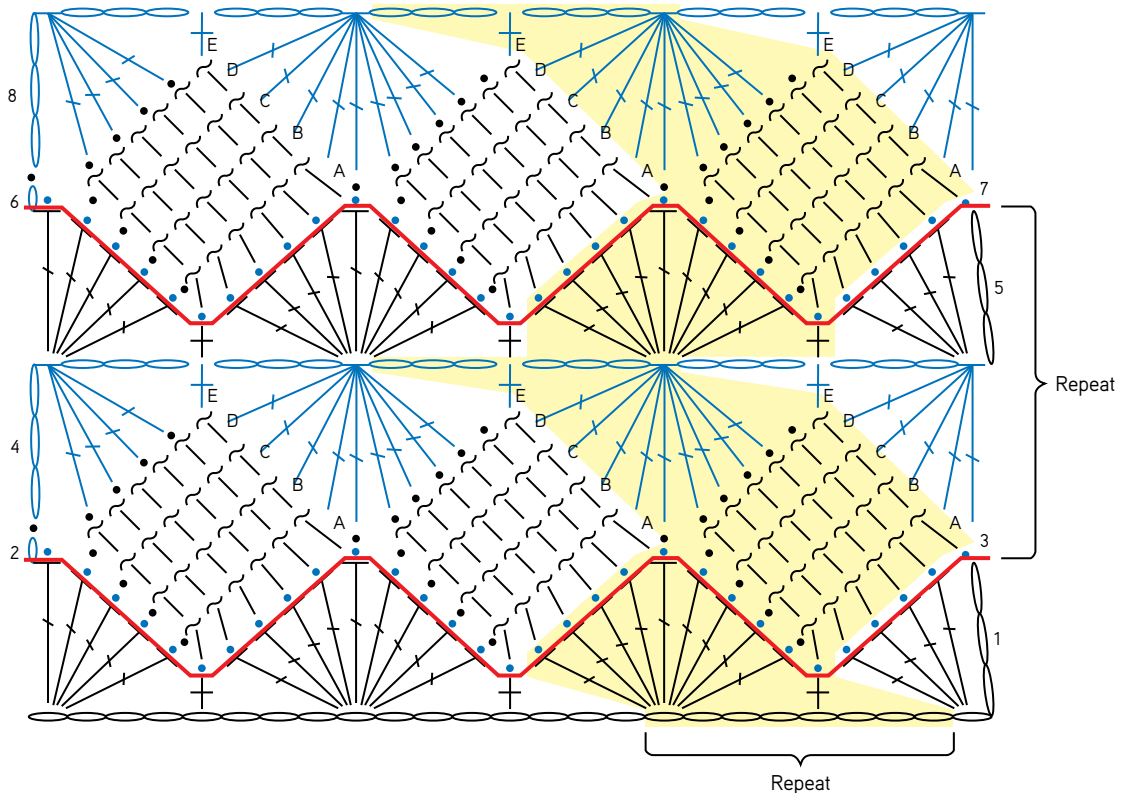

Rep Rows A–E of Tunisian square across, working last sl st in top of tch, turn.

ROW 4 (STANDARD CROCHET): Ch 3 (counts as dc), inserting hook under sl sts of Row E of square, dc4tog over next 4 sl sts, *ch 3, sc in next top corner Tss, ch 3**, dc9tog over next 4 row-end sts and next 5 sl sts; rep from * across, ending last rep at **, dc4tog over next 4 row-end sts and top of tch, turn.

ROW 5: Ch 3 (counts as dc), 4 dc in first st, *sk next ch-3 sp, sc in next sc, sk next ch-3 sp**, 9 dc in next cluster; rep from * across ending last rep at **, 5 dc in last cluster, turn.

Rep Rows 2–5 for patt, ending with Row 4.

Stitch 33

Marguerites are a floral stitch pattern that fits particularly well with Tunisian crochet. The number of rows between rows of Marguerites can be varied to any number.

NOTE: Check the placement of sts in Rows 6 and 7 carefully. This is crucial to keep marguerites lined up in later rows and to keep edges of work straight.

Multiple of 2 plus 1 sts.

Work basic foundation row (see Glossary).

ROWS 1-2 (TUNISIAN): *Fwd:* Tss in each st across, draw up lp in last bar. *Rtn:* Work basic rtn pass (see Glossary).

ROW 3 (STANDARD CROCHET): Ch 2, draw up lp in 2nd ch from hook, draw up lp in first 3 bars, yo, draw through 5 lps on hook, ch 1 (eye), *draw up lp in eye, draw up lp 1 st back (same bar as last st), draw up lp in next 2 bars, yo, draw through 5 lps, ch 1 (eye); rep from * across, turn (*Note:* you should have half the number of starting chs minus 1 marguerite).

ROW 4 (STANDARD CROCHET): Ch 1 (counts as hdc), hdc in first eye, *2 hdc in next eye; rep from * across, hdc in top of tch, ch 1, turn (*Note:* you should have the same number of hdc as Tss in Row 1).

ROW 5 (TUNISIAN): *Fwd:* Sk first hdc, draw up lp in each hdc across, draw up lp in tch (ch-1 at start of last row). *Rtn:* Work basic rtn pass.





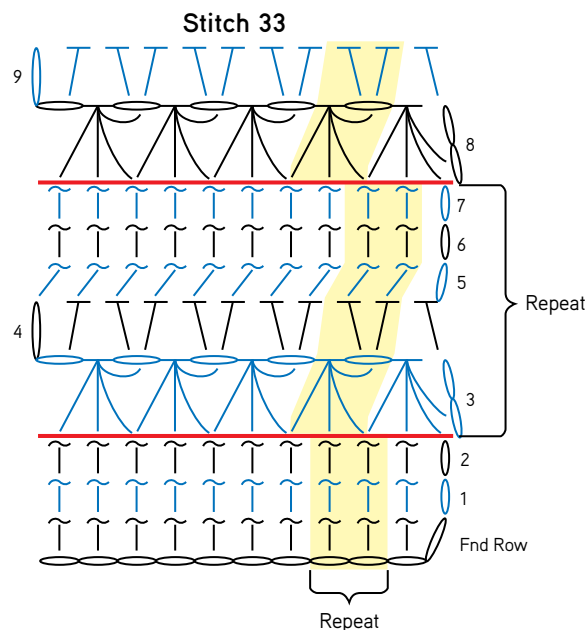















ROWS 6-7 (TUNISIAN): *Fwd:* Tss in each st across, draw up lp in last bar. *Rtn:* Work basic rtn pass.



















Rep Rows 3-7 for patt.











SYMBOL KEY







Forward Symbols

-  Tss
-  Tks
-  Tps
-  Tfs
-  Tdc
-  Ttr
-  Tunisian bobble
-  draw up a lp in back bump
-  Puff st
-  ch 1
-  yo
-  Tunisian extended st (Tes)
-  Tunisian reverse st (Trs)
-  draw up lp in 2 lps of ch
-  TwTss
-  Back-twisted Tss (Bts)
-  Ttr3tog in vertical bar and back bump
-  Tks, ch 2
-  Tks in next ch, ch 2
-  Tss, ch 2











-  Tss3tog
-  3 Tdc shell (sh)
-  Left-cross 2 x 2 cable
-  Right-cross 2 x 2 cable
-  Left-cross 2 x 1 cable
-  Right-cross 2 x 1 cable
-  Tunisian crossed st
-  Tes2tog
-  Tss2tog
-  Tdc with hook inserted under 2 loops.
-  2 Tdc in same st
-  2 Tdc in top of fan
-  3 Tdc in top of fan
-  yo, work 3 Tss, bring 4th lp to the right over last 3 lps and over end of hook
-  Tss, yo, Tss, yo, Tss
-  sk 3 sts, Tss in next 3 sts, Tss in 3 skipped sts
-  Long Tss
-  Long Tdc

-  Long Ttr
-  Ttr3tog (claw)
-  Long Puff st
-  long st in top 2 lps of st
-  Right Half Triangle
-  Left Half Triangle
-  Triangle
-  Fan

Return Symbols

-  yo, draw through 1 lp for first st, yo, draw through 2 lps for each rem st
-  ch 1
-  yo, draw through 3 lps on hook
-  yo, draw through 4 lps on hook
-  yo, draw through 4 lps on hook
-  yo, draw through 6 lps on hook

Standard Crochet Symbols

-  chain (ch)
-  slip st (sl st)
-  single crochet (sc)
-  half double crochet (hdc)
-  double crochet (dc)
-  Yo, [draw up lp in next ch or sp] twice, yo, draw yarn through 3 lps and draw up lp to 1/2" (1.3 cm)
-  Marguerite st
-  dc4tog
-  dc5tog
-  dc9tog

GLOSSARY

Abbreviations

beg	begin/beginning	sc	single crochet
blp	back loop/back loop only	sh	shell
ch	chain	sk	skip
dc	double crochet	sl st	slip stitch
dec	decrease/decreases/decreasing	sp(s)	space(s)
est	established	st(s)	stitch(es)
flp	front loop/front loop only	tch	turning chain
fol	follow/follows/following	TC	Tunisian crochet
fwd	forward pass	Tdc	Tunisian double crochet
hdc	half double crochet	Tfs	Tunisian full stitch
inc	increase/increases/increasing	Tks	Tunisian knit stitch
lp(s)	loop(s)	tog	together
patt	pattern	Tps	Tunisian purl stitch
pm	place marker	tr	treble crochet
rem	remain/remaining	Tslst	Tunisian slip stitch
rep	repeat/repeats	Tss	Tunisian simple stitch
rnd(s)	round(s)	Ttr	Tunisian treble crochet
RS	right side	Ttw	Tunisian twisted stitch
rtn	return pass	WS	wrong side
rep	repeat	yo	yarn over

CROCHET CHAIN (CH)

Make a slipknot and place it on crochet hook, *yarn over and draw through loop on hook; repeat from * for the desired number of chains.



SINGLE CROCHET (SC)

Insert hook in stitch, yarn over and pull up a loop, yarn over and draw through both loops on hook.

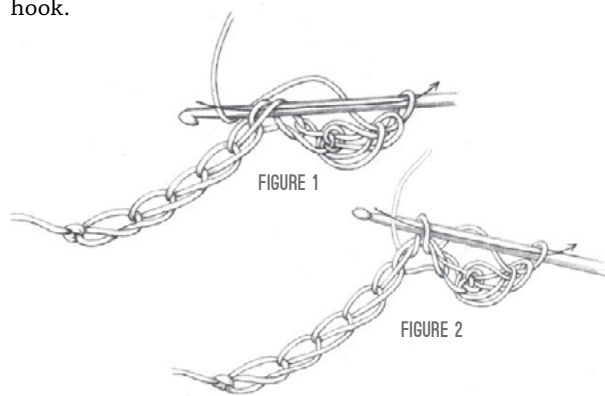

DOUBLE CROCHET (DC)

Yarn over, insert hook in stitch, yarn over and pull up a loop (3 loops on hook), yarn over and draw through 2 loops on hook, yarn over and draw through remaining 2 loops on hook.

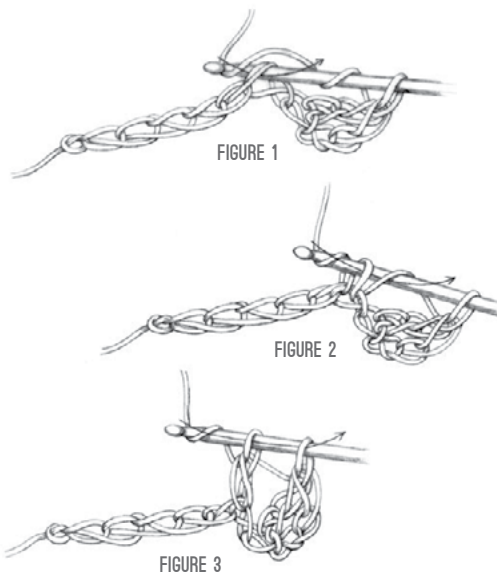

TREBLE CROCHET (TR)

Yarn over twice, insert hook in stitch, yarn over and pull up a loop (4 loops on hook), yarn over and draw through 2 loops, yarn over and draw through the next 2 loops, yarn over and draw through remaining 2 loops on hook.

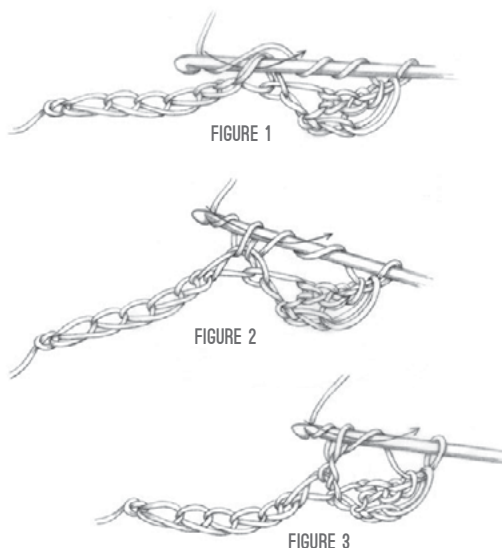

HALF DOUBLE CROCHET (HDC)

Yarn over, insert hook in stitch, yarn over and pull up a loop (3 loops on hook), yarn over and draw through all loops on hook.

MATTRESS STITCH

With RS facing, use threaded needle to *bring the needle through the center of the first stitch or post on one piece, then through the center of the corresponding stitch or post of the other piece; repeat from * to end of seam.

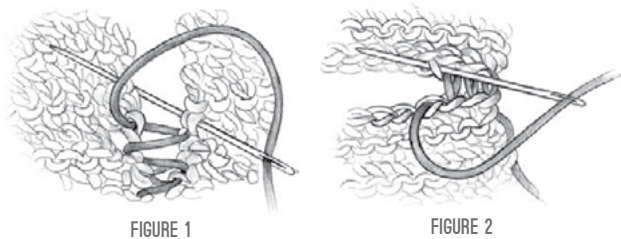

BASIC TUNISIAN FOUNDATION ROW

Chain any number. *Fwd*: Draw up lp in blp or back bump of 2nd ch from hook and each ch to end. *Rtn*: Yo, draw through 1 lp, *yo, draw through 2 lps; rep from * to end.

BASIC RETURN PASS

Yo, draw through 1 lp, *yo, draw through 2 lps; rep from * to end.

TUNISIAN SIMPLE STITCH (TSS)

ROW 1 (RS): *Fwd*: Pull up a loop in 2nd chain from hook and in each chain across. *Rtn*: Yarn over and draw through 1 loop on hook, *yarn over and draw through 2 loops on hook; repeat from * to end.

ROW 2: *Fwd:* (loop on hook counts as first st)

**Insert hook in vertical bar of next stitch and pull up a loop; rep from * across. Rtn:* Yarn over and draw through 1 loop on hook, **yarn over and draw through 2 loops on hook; repeat from * to end.*

Repeat Row 2 to desired length.

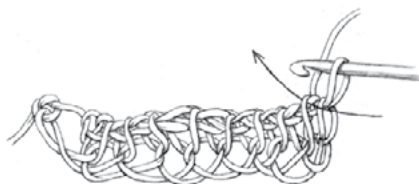

FIGURE 1

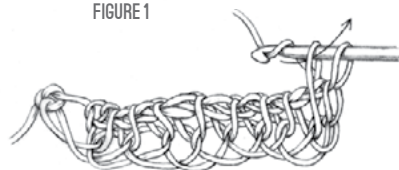

FIGURE 2

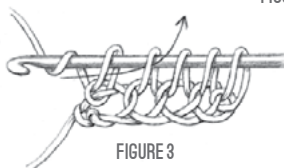

FIGURE 3

TUNISIAN KNIT STITCH (TKS)

ROW 1 (RS): *Fwd:* Pull up a loop in 2nd chain from hook and in each chain across. *Rtn:* Yarn over and draw through 1 loop on hook, **yarn over and draw through 2 loops on hook; repeat from * to end.*

ROW 2: *Fwd:* (loop on hook counts as first st):

**Insert hook from front to back between front and back vertical bars and under all horizontal loops of designated stitch, yarn over and pull up a loop; rep from * across. Rtn:* Yarn over and draw through 1 loop on hook, **yarn over and draw through 2 loops on hook; repeat from * to end.*

Rep Row 2 to desired length.



TUNISIAN PURL STITCH (TPS)

ROW 1 (RS): *Fwd:* Pull up a loop in 2nd chain from hook and in each chain across. *Rtn:* Yarn over and draw through 1 loop on hook, **yarn over and draw through 2 loops on hook; repeat from * to end.*

ROW 2: *Fwd:* (loop on hook counts as first st):

**Move yarn to front of work, insert hook in vertical bar of next stitch, yarn over and pull up a loop; repeat from * across. Rtn:* Yarn over and draw through 1 loop on hook, **yarn over and draw through 2 loops on hook; repeat from * to end.*

Rep Row 2 to desired length.

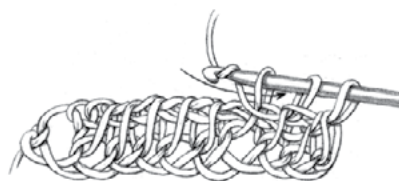

TUNISIAN FULL STITCH (TFS)

ROW 1 (RS): *Fwd:* Pull up a lp in 2nd ch from hook and in each ch across. *Rtn:* Yo and draw through 1 lp on hook, **yo and draw through 2 lps on hook; rep from * to end.*

ROW 2: *Fwd:* (lp on hook counts as first st): Insert hook between next 2 vertical bars and draw up a lp; rep from * across. *Rtn:* Yo and draw through 1 lp on hook, **yo and draw through 2 lps on hook; repeat from * to end.*

Repeat Row 2 to desired length.

TUNISIAN SLIP STITCH (TSLST)

Insert hook as instructed in pattern, draw lp through st and lp on hook.